

УДК 621.316

## THE NEW WAY IN DIGITAL PROTECTIVE RELAYS DESIGNING

V. Gurevich

Honorable professor Central Electric Laboratory, Israel Electric Corp.,  
e-mail: vladimir.gurevich@gmx.net

*Transition from electromechanical to digital protective relays is accompanied with serious technical problems. The author offers the new approach in designing the digital relays, capable to solve these problems. This approach is based on similarity of functional units of digital relays and personal computers. It is offered to carry out digital relays in the form of standard modules from which it would be possible to assemble the digital relay in the same way as now a personal computer.*

**Key words:** digital protective relays, electromechanical relays, reliability of relay protection.

Massive power grid failures (blackouts), leading to huge losses and often to death (USA: 1965, 1977, 2003, France: 1978, Canada: 1982, 2003, Italy: 2003, Sweden: 1983, 2003). Malfunction protective relays is one of the main causes of the heavy failures that periodically occur in power systems all over the world. According to the North American Electric Reliability Council in 74 % cases the reason of heavy failures in power systems was the incorrect actions of relay protection in trying to avoid the failure. Thus the reliability of a power system depends on the reliability of relay protection in many respects.

In previous publications the author has already analyzed the transition from electromechanical to a microprocessor-based protective relays, and considered the prospects and problems of microprocessor relays applications [1, 2]. The rather sharp reaction of the readers, often arising after these publication, on the one hand, and the author's detailed answers to the criticism of opponents on the other show that among the specialists in this area there is no common opinion about the prospects of microprocessor protection, there is no unequivocal understanding that, as any other complex device, the microprocessor protection not only possesses obvious advantages, but also has serious weaknesses.

One of the widely widespread fables [3, 4] justifying the inevitability of transition to Digital Protective Relays (DPR) is the myth that electromechanical protective relays do not provide for the performance of the technical requirements for relay protection and the continuing existence of electric power industry of today is not possible without DPR

Actually, no new functions in relaying DPR have been introduced. The parameters and facilities of the high-quality electromechanical and semiconductor, that is, the static analog devices con-

structed on the basis of discrete solid-state elements and integrated microcircuits, completely provide all relay protection requirements. In relaying there are no actual problems that could not be solved by means of electromechanical or static relays (note: recording emergency modes is not relay protection function). Confirmation of this is the fact that branched and complex electrical networks and systems exist and successfully function all over the world, and have for more than hundred years; whereas microprocessor-based relay protection has appeared in use in not very appreciable numbers just 10-15 years ago. Thus, with the beginning of the use of DPR the functioning logic of an electric power system has not changed, the number of operations that are carried out by an electric power system has not increased, the quantity of the produced electric power has not changed, principles of transmission and distribution of the electric power have not changed.

#### Some conclusions from previous author publications [1-4]:

1. Reliability DPR is lower than reliability of electromechanical relays and electronic relays on discrete elements.
2. Built-in self-diagnostics DPR is ineffective and is not a means at all for increasing of MPD reliability.
3. Nanotechnologies, used at manufacture of DPR's elements, leads to the occurrence of problems not known earlier for relay protection. Ignoring these problems can lead to catastrophic consequences. The managers making of the decision in the field of relay protection and the personnel of the power companies should be informed about these DPR features.
4. The recording function of emergency modes in power network and data transmission function

on modern connection channels are not direct functions of relay protection and for their realization there are separate microprocessor devices which carry out these functions much better than DPRs. As against relay protection, failure of these devices does not lead to heavy failures in power systems. Therefore for relay protection devices the focus should be on other demands on reliability and, accordingly, to use other approaches at the designing, directed on increasing of reliability and decreasing in vulnerability.

5. The persons responsible for making the decisions on reconstruction of relay protection and ways of further developments should understand, precisely, the properties and features of the DPR, to take into account not only widely promoted DPR advantages, but also the serious lacks, one of which is lowered reliability.

#### So, what to do with all these problems?

To answer that question we should look at the construction of DPD. As is known, the DPD has a modular design. The basic functional units of DPD are: motherboard with an analog-to-digital converter, microprocessor, various types of memory and other accessories; digital (logic) inputs with photocouplers module; analog inputs based on the current and voltage transformers module; output relays module. Isn't this modular design of DPD similar to that of personal computer (PC)? However, there is one significant and even essential difference between PC and DPD: each PC module is available on the open market and you can assemble your PC with modules produced by different manufacturers from different countries. What does it lead to? It leads to price reduction and ability to assemble a PC with the best suited modules regarding their characteristics and price. The same applies to the software. There is some universal platform (Windows) and a huge market of applications for every taste.

But, are there any significant structural differences between the PC and the DPD? In reality, there are few essential differences it uses the same power source, the same main module (motherboard) connected to auxiliary modules, such as the analog inputs module (a set of CT and VT with the filter and ADC) - instead of the video card, logic inputs module - instead of the TV Tuner, output relays module - instead of the sound card. What is the essential difference between the software designed for multifunctional DPDs and any other software? There is no difference! So what's the problem? Why do we have now a vast number of totally non-interchangeable DPD designs, instead of a set of universal modules in the form of printed circuit boards.

Why do we have a wide variety of the DPD software versions that are inconsistent even with each other?



Fig. 1

To answer this question, let's trace how this remarkable business works. For example, what happens if some specific module of a specific DPD type at a given substation fails? This is what. Since there is no market for universal modules, **the user can replace the failed module only and exclusively by the same one, produced by the same manufacturer.** Thus, after you spent a small fortune to purchase the DPD from one of the manufacturers, you actually fall into the bondage of economic dependence on this manufacturer for the next 10 - 15 years, since after you have chosen one manufacturer it no longer matters if there are other manufacturers on the market as you can not use their products.



Fig. 2 The modern method of mounting the DPD in relay cabinets

And the only way to get out is to pay a small fortune one more time for the DPD from another manufacturer (and, thus, you go from one bondage to another). And what does the manufacturer in such situation of absolute monopoly do? Right: the manufacturer increases the price! The price of one spare DPD module can reach almost one-third or even a half of the price of the entire DPD! As you have nowhere to go, you pay that price. And what

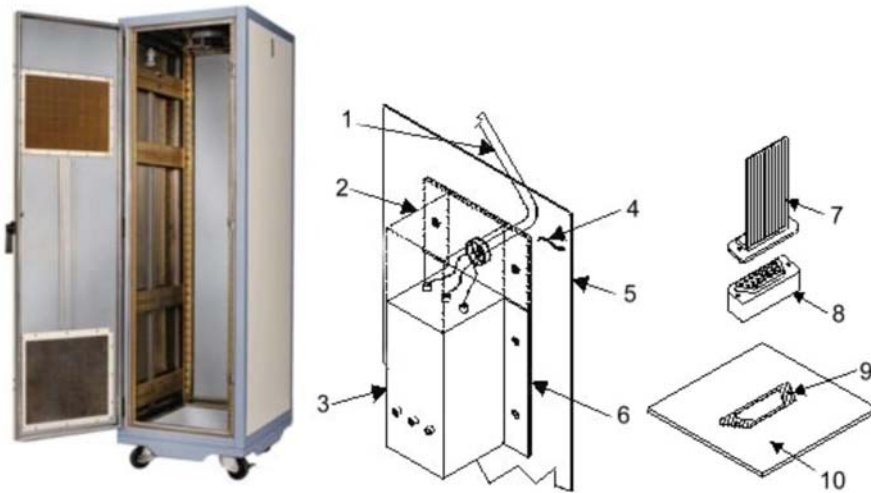

Fig. 3

happens after 8 - 10 years of the DPD operation? Here's what happens: the manufacturer had already developed several new designs during that time and it has become unprofitable for the manufacturer to maintain the facilities producing spare modules for the old relays, so production has been stopped. What does the consumer do in this situation? Right: throw the old DPD into the garbage, even if there is only one faulty module (printed circuit boards of the modern DPD are developed by the irreparable technologies), and shell out for purchasing a new one. Who wins? Right, the same manufacturer! But why the manufacturer is allowed to cash in on the consumer in any conditions? What should have been done to turn the tide in favor of the consumer? That's right, the DPD should be realized as a set of the modules - circuit boards with universal standard dimensions and connectors, just like those for PC, and with integrated basic program shell compatible with the software for the given type of the protection or the protection kit, available on the market. Today each type of DPD has its own body which significantly differs from that of any other DPD type, sometimes even from the same manufacturer, Fig.1.

Today as a rule, a single DPD is installed in the relay cabinets: 3 - 5 units in the each cabinet, Fig. 2. If a new DPD will be realized as a set of universal modules on the printed circuit boards, then such sets (at least, in most cases) will not require the individual cases. Each DPD may be installed as a single horizontal section in the cabinet with the printed circuit board guiderails, individual door and the rear wall with connectors and terminals for connecting external cables just as in PCs.

The relay cabinet should be made by special technology intended to protect its contents from electromagnetic influences. There are modern technologies (special cases, electrically conductive pads and greasing, filters, etc.), which could significantly reduce the effect of external electromagnetic emission of wide frequency range on high-sensitive DPD equipment, Fig.3.

The proposed tendency of development could open the DPD market to new "players" some of whom could produce analog input modules equipped with current and voltage transformers, others – motherboards, or software. The consumer could "build" the DPD out of the separate modules from different manufacturers, just as it is today for PC, based on the cost and quality of these modules, as well as use the same software for all its DPD s. It would solve many of the questions set out above, and significantly reduce the cost of relay protection.

This could also enable installing two sets of identical DPD s instead of one in order to improve the reliability, and use the second set as backup, starting automatically upon the "watchdog" signal of the damaged core DPD. In addition it would eliminate the necessity of the individual power source for each DPD, and allow using one double high-capacity power source set of improved reliability for the entire cabinet. And finally this would allow installing many service modules, capable of improving the DPD reliability, in the same cabinet.

Thus the relay protection maintenance would be simpler as the service staff would not need to read thick folios (Fig. 4) about different DPDs installed in the facility and study characteristics of the software of each DPD type.



Fig. 4 Thick folios containing user information about DPD

In addition to easier maintenance and reducing the new DPD lead time, it would significantly reduce the percentage of errors caused by the so-called "human factor". Such DPD design would solve also the problems of testing complex DPD functions [5].

How can such new way of DPD reconstruction described above be realized in practice? The easiest way is to start in one big country with a large market and several DPD manufacturers able to close with each other. In our opinion, the first step

in this direction should be the setting of national standards containing requirements of the new type of DPD, its software, test procedures, etc. These standards must be developed by a wide range of professionals, including scientists, potential DPD producers, their potential customers and representatives of project organizations. It seems that such relay protection development, even in one country, would show an example to be emulated around the world.

### References

1. Gurevich V. Microprocessor Protection Relays: New Prospects or New Problems? / V. Gurevich // Electr. Engineering and Electromechanics. – 2006. – N 3. – P. 18–26.
2. Gurevich V. Microprocessor Protection Devices – The Present and the Future / V. Gurevich // Serbian Journal of Electr. Engineering. – 2008. – V. 5, No. 2. – P. 325–339.
3. Gurevich V. Reliability of Microprocessor-Based Protective Devices – Revisited / V. Gurevich // Journal of ELECTRICAL ENGINEERING (Engl). – 2009. – Vol. 60, No. 5.
4. Gurevich V. Reliability of Microprocessor-Based Relay Protection Devices – Myths and Reality / V. Gurevich // Engineer IT. Part I: 2008. – N 5. – P. 55 – 59 ; part II: 2008. – N 7. – P. 56–60.
5. Gurevich V. Tests of Microprocessor-Based Protection Devices / V. Gurevich // Energize. – 2008. – N 5. – P. 19–21.

## НОВОЕ НАПРАВЛЕНИЕ В КОНСТРУИРОВАНИИ МИКРОПРОЦЕССОРНЫХ РЕЛЕ ЗАЩИТЫ

В.И. Гуревич

*Переход от электромеханических к цифровым реле защиты сопровождается появлением множества серьезных технических проблем. Автор предлагает новый подход в конструировании цифровых реле, способный решить эти проблемы. Этот подход основан на принципиальном сходстве функциональных блоков цифровых реле и персональных компьютеров. Предлагается выполнять цифровые реле в виде стандартных модулей, из которых можно было бы набирать цифровое реле защиты точно так же, как сейчас персональный компьютер.*

*Ключевые слова: микропроцессорные реле защиты, электромеханические реле, надежность релейной защиты.*